



ELECTRIC ACTUATED TRUE UNION BALL VALVES

Spears® True Union 2000 Ball Valve Premium Electric Actuation Package

The compact design of True Union 2000 Ball Valves provides maximum versatility with minimum space requirements. Fully serviceable valve cartridge also mates with Spears® Union 2000 Schedule 80 pipe unions. Both valves and unions utilize Buttress Thread union nuts for superior strength. All ball valves feature Spears® self adjusting Floating Seat design for extended service, and Spears® Safe-T-Shear® Stem with double O-ring stem seals for assurance of fluid containment in case of inadvertent valve damage. Available in chemical and corrosion resistant PVC or CPVC with socket, flanged or Spears® Patented Special Reinforced (SR) threaded.

Actuated package includes polypropylene valve mounting bracket for accurate valve/actuator alignment and support in any position. Premium electric actuator utilizes a reversing type motor with UL approved, built in thermal overload protection. Gear train is permanently lubricated with manual override standard. Enclosure is corrosion resistant polyester powder coated aluminum, weatherproof NEMA 4 rating, 1/2" NPT conduit outlet. All hardware is stainless steel. Includes 2-SPDT limit switches pre-wired for standard 115 VAC, 60 HZ.



Declutchable Style Shown

True Union 2000 Ball Valve Specifications

Style	Double union • 1/4 turn shut off • Double O-ring stem seals • Safe-T-Shear® Stem • Blocked seal carrier
Material	PVC or CPVC
Size Range	1/2" - 6" & 8" Venturied*
Pressure Rating	1/2" - 4" = 235 psi @ 73° F 6" - 8" & all flanged valves = 150 psi @ 73° F
Vacuum Service Seats	To 26 in-Hg PTFE
O-rings	EPDM or Viton®
End Connector	Socket, SR Threaded, or Flanged
Certifications	EPDM Valves NSF Certified for potable water use.

*8" Venturied is 6" valve fitted with 8 x 6 adapters

Custom Electric Actuation Options & Accessories

- Modulating (variable positioning)
- Heater & Thermostat
- Additional Limit Switch sets
- Position Indicator
- LED Indicator lights
- Torque Sensor
- Declutchable Manual Override (Standard 2-1/2" - 6")
- Duty Cycle Upgrades (75% & 100%)
- NEMA 4x, 7, & 9 Enclosures
- Spring Return Operation (Fail Safe)
- Voltage Options: 24 VAC, 230 VAC, 12 VDC, 24 VDC

Note: Modulation requires special enclosure for 1/2" - 2" valves.

Standard Actuator Specifications

Motor Thermal Overload Protection	Reversing	
Cycle Time	Standard	
	1/2" - 2"	= 2.5 sec.
	2-1/2" - 3"	= 5.0 sec.
	4" - 6"	= 15.0 sec.
Duty Cycle	1/2" - 2"	= 75%
	2-1/2" - 6"	= 25%
Lock Rotor Current	1/2" - 2"	= 0.55 amps
	2-1/2" - 3"	= 0.75 amps
	4"	= 0.75 amps
	6"	= 1.10 amps
Manual Override Limit Switch Enclosure	Standard (Declutchable 4" - 6") 2, SPDT NEMA 4 1/2" NPT connection	
Material/Finish	Aluminum/Powder Coated	
Voltage	115 VAC, 60 Hz	
Lubrication	Permanent	

Sample Engineering Specification

All ball valves shall be electrically actuated True Union 2000 type constructed from PVC Type I Cell Classification 12454 or CPVC Type IV Cell Classification 23447. All O-rings shall be EPDM or Viton®. All valves shall have Safe-T-Shear® stem and double O-ring stem seals. All valve union nuts shall have Buttress threads. All seal carriers shall be Safe-T-Blocked®. All valve components shall be replaceable. All EPDM valves shall be certified by NSF international for use in potable water service. All 1/2" through 4" valves shall be pressure rated at 235 psi and all 6" through 8" & all flanged valves shall be pressure rated at 150 psi for water at 73° F. Electric Actuators shall be factory installed, 115 VAC with thermally protected, reversing motor and powder coated NEMA 4 rated enclosure. All mounting fasteners shall be stainless steel. Actuator shall be equipped with [selected options list], as manufactured by Spears® Manufacturing Company.

TRUE UNION BALL VALVES - ELECTRIC



Standard Package Dimensional Information:

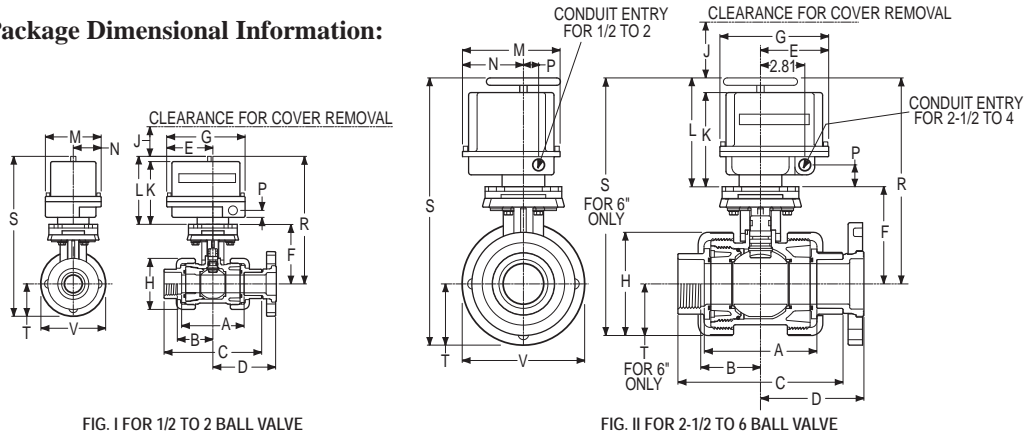

FIG. I FOR 1/2 TO 2 BALL VALVE

FIG. II FOR 2-1/2 TO 6 BALL VALVE

NOMINAL SIZE	A	B	C		D	E	F	G	H	J	K
			SOCKET	THREAD							
1/2	2.44	1.19	4.19	3.81	2.95	3.31	1.76	5.62	1.88	2.50	4.50
3/4	2.75	1.40	4.75	4.25	3.32	3.31	2.01	5.62	2.25	2.50	4.50
1	2.88	1.45	5.13	4.69	3.57	3.31	2.21	5.62	2.50	2.50	4.50
1-1/4	3.25	1.66	5.75	5.19	3.82	3.31	2.79	5.62	3.06	2.50	4.50
1-1/2	3.50	1.77	6.25	5.44	4.16	3.31	3.00	5.62	3.50	2.50	4.50
2	4.75	2.39	7.75	6.75	5.00	3.31	3.69	5.62	4.25	2.50	4.50
2-1/2	6.95	3.47	10.44	9.68	6.70	4.45	5.39	6.88	6.19	3.00	5.38
3	6.95	3.47	10.69	9.75	6.98	4.45	5.39	6.88	6.19	3.00	5.38
4	7.31	3.64	11.87	10.25	7.44	4.62	5.82	7.00	7.50	4.00	6.75
6	11.03	5.50	17.13	15.75	10.15	4.62	9.29	7.00	11.63	4.00	6.75

NOMINAL SIZE	L		M	N	P	R		S		T	V	FIG.
	DISENGAGED	ENGAGED				DISENGAGED	ENGAGED	DISENGAGED	ENGAGED			
1/2	N/A	4.88	4.00	2.00	1.31	N/A	6.64	N/A	7.83	1.19	3.54	I
3/4	N/A	4.88	4.00	2.00	1.31	N/A	6.89	N/A	8.24	1.35	3.54	I
1	N/A	4.88	4.00	2.00	1.31	N/A	7.09	N/A	8.56	1.47	3.54	I
1-1/4	N/A	4.88	4.00	2.00	1.31	N/A	7.67	N/A	9.47	1.80	4.13	I
1-1/2	N/A	4.88	4.00	2.00	1.31	N/A	7.88	N/A	9.88	2.00	4.53	I
2	N/A	4.88	4.00	2.00	1.31	N/A	8.57	N/A	10.88	2.31	5.10	I
2-1/2	8.62	8.22	4.25	2.12	1.00	14.01	13.61	17.13	16.73	3.12	7.00	II
3	8.62	8.22	4.25	2.12	1.00	14.01	13.61	17.13	16.73	3.12	7.00	II
4	9.25	9.15	7.00	4.38	1.56	15.07	14.97	19.17	19.07	4.10	8.50	II
6	9.25	9.15	7.00	4.38	1.56	18.54	18.44	24.36	24.26	5.82	11.25	II

Electric Actuator Wiring Diagram

Rotary Electric Actuator

Field Wiring

- T1 Neutral
- T2 To open valve
- T3 To close valve
- T4 Light indication for open position
- T5 Light indication for closed position

Operation

- Power to T1 and T2 will open valve (120VAC)
- Power to T1 and T3 will close valve (120VAC)
- Light connected to T1 and T4 indicates open
- Light connected to T1 and T5 indicates closed

